

DO NOT
THROW AWAY!

TOOLS

		 11mm	 4mm & 5mm	 PRIMER	 GREASE	
 SILICONE SPRAY		 ISOPROPYL ALCOHOL	 Ø30mm & Ø50mm		 CLEAN CLOTH	 RUBBER HAMMER
	 SCISSORS					

INSTALLATION INSTRUCTIONS

UNPACKING THE PRODUCT

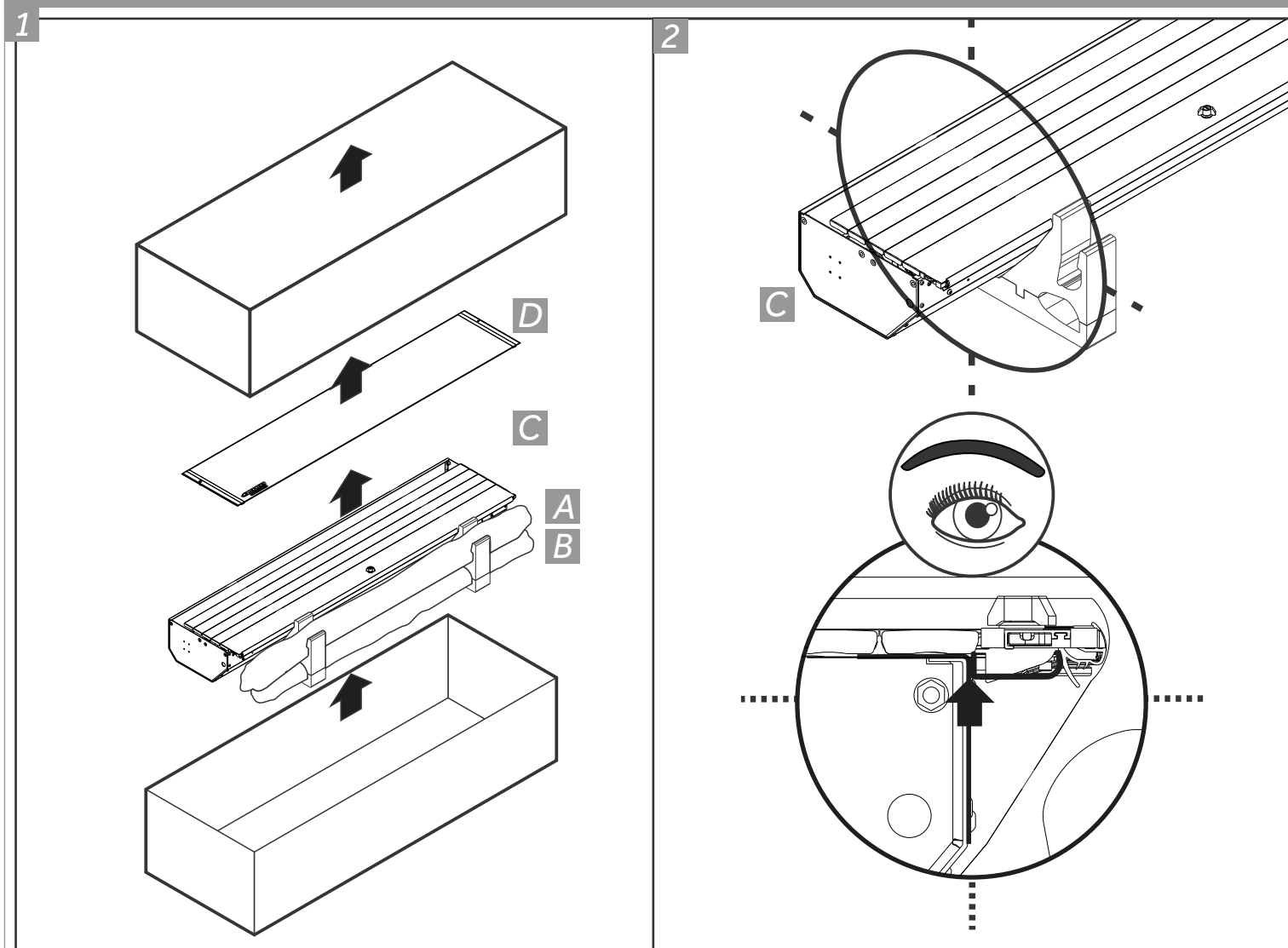

INSTALLATION INSTRUCTIONS

3

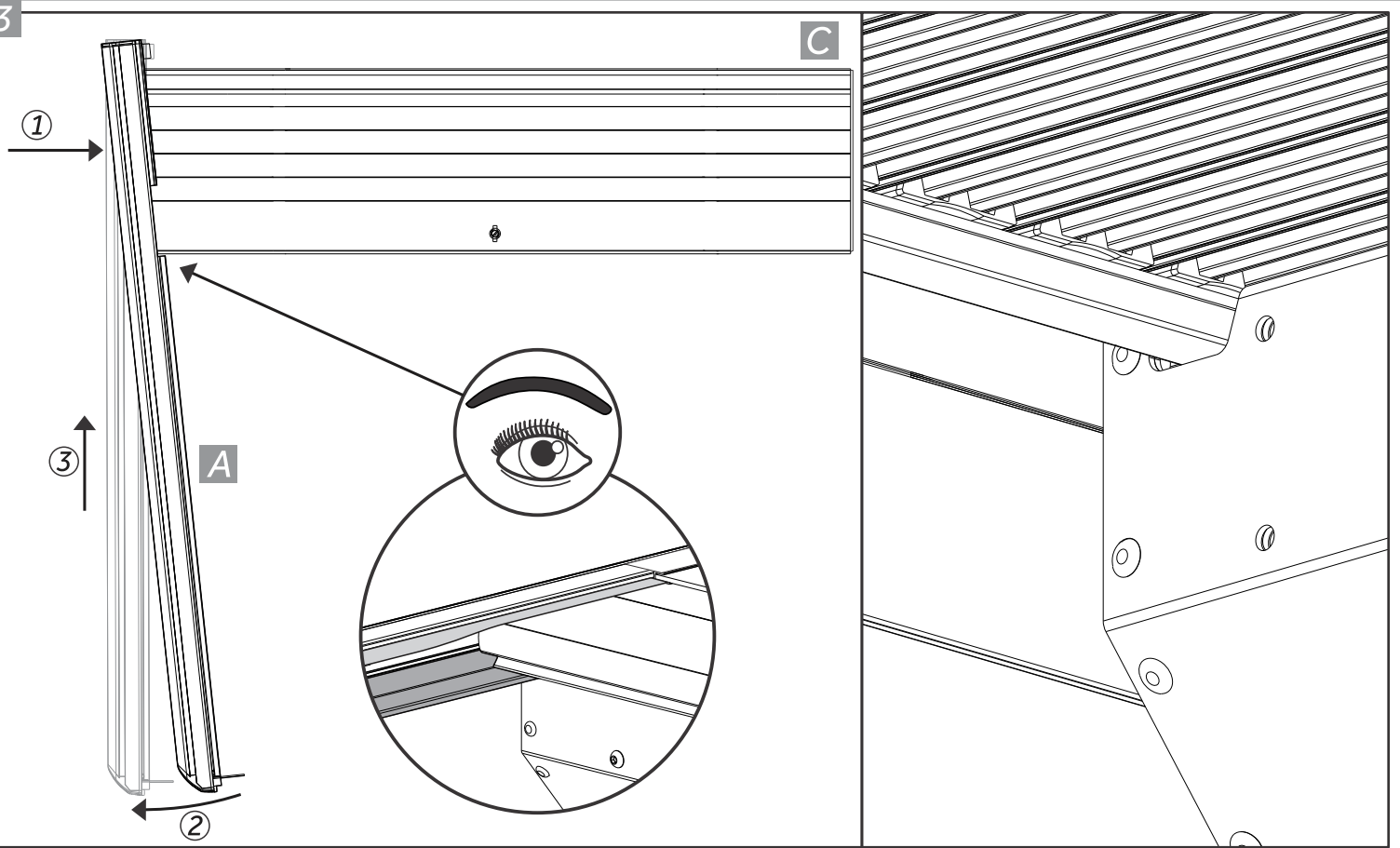

4

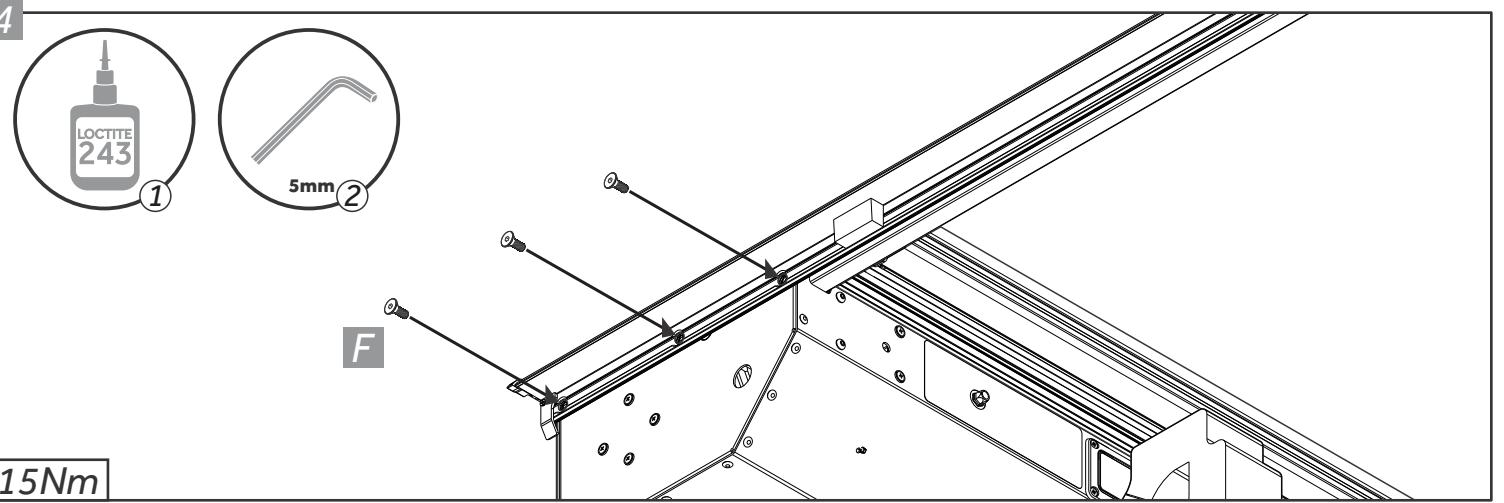

5

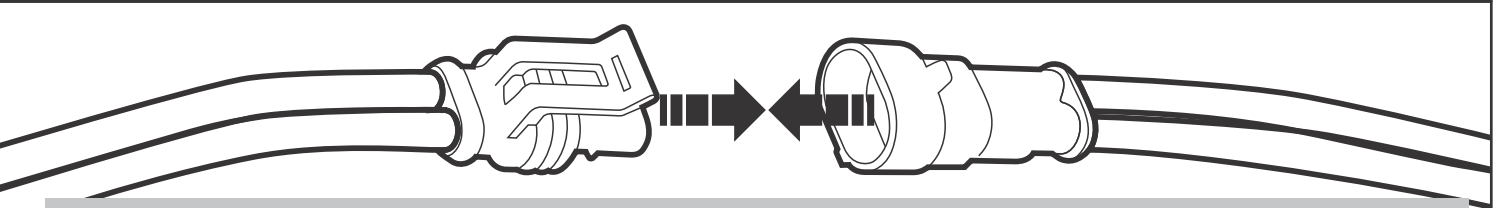
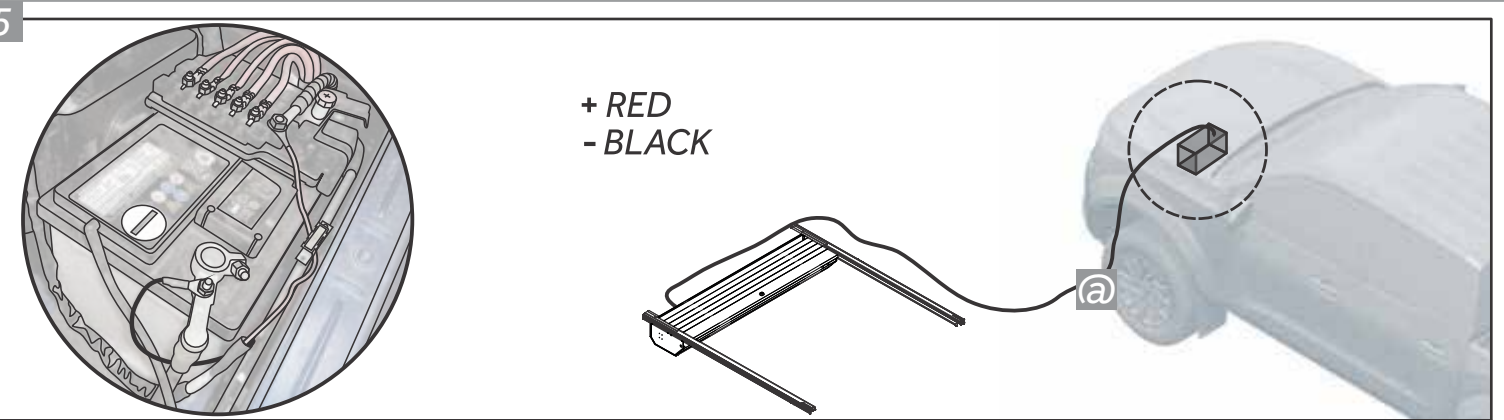

If you require further help or guidance please contact us +64 9 582 0000

INSTALLATION INSTRUCTIONS

6

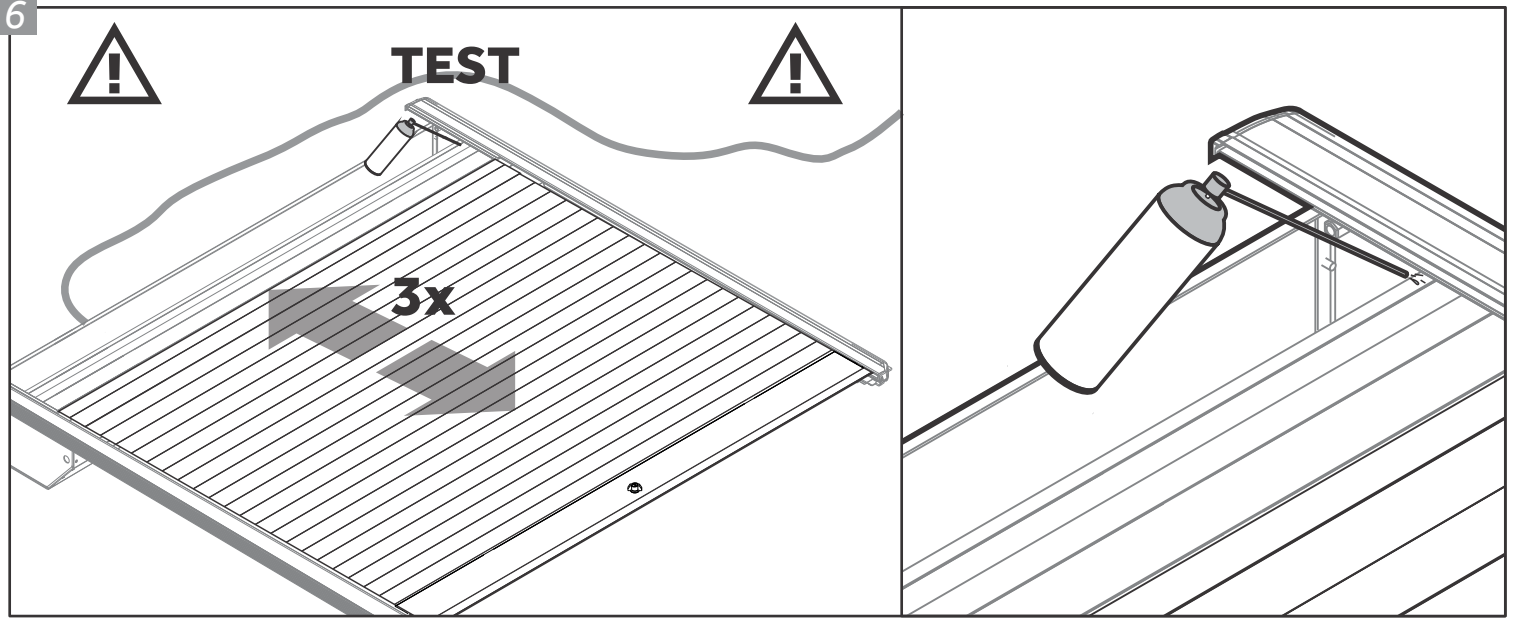

7

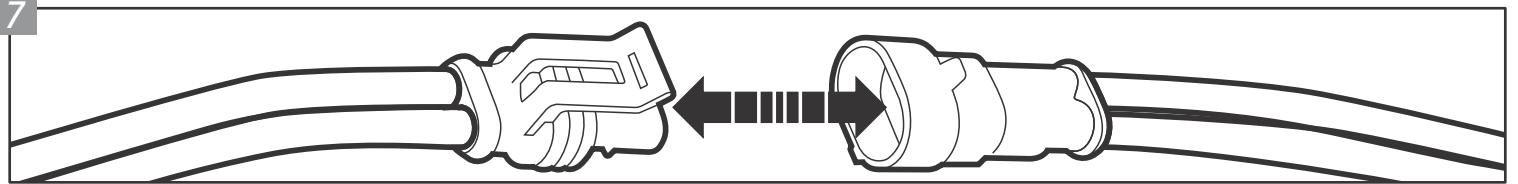

8

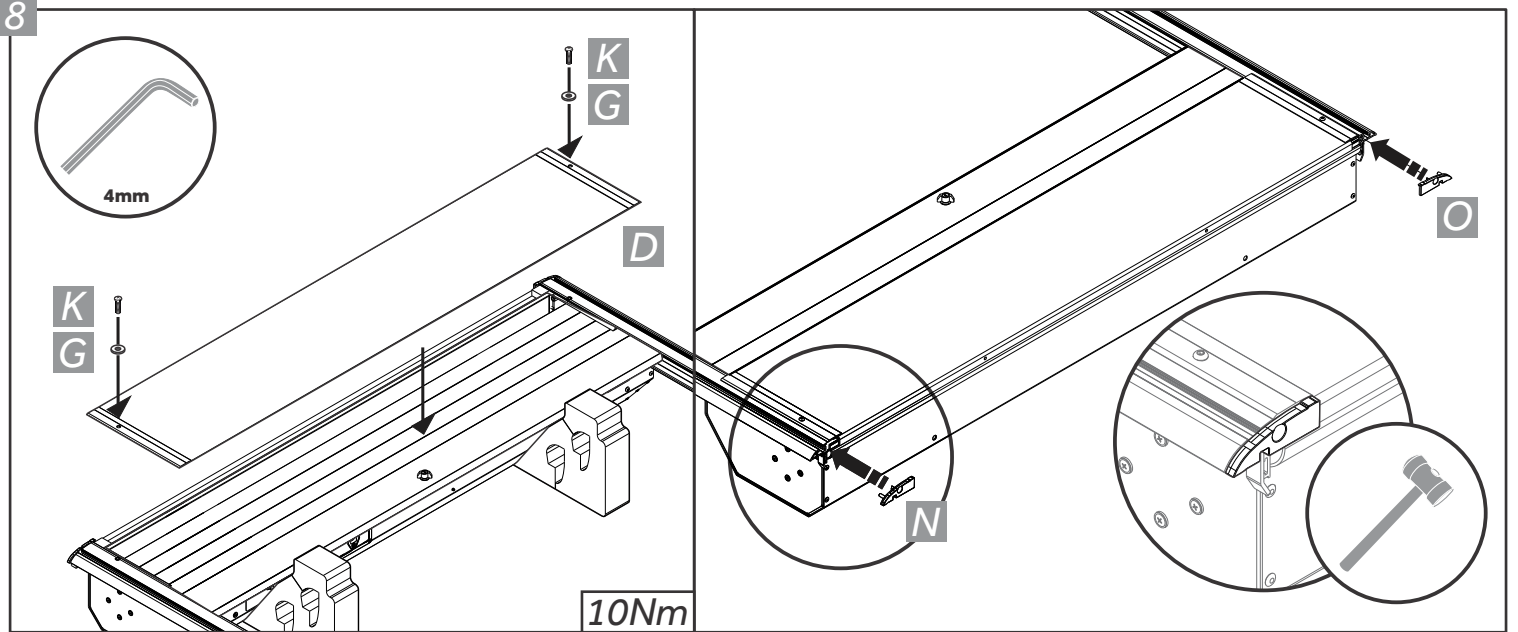

9



INSTALLATION INSTRUCTIONS

10

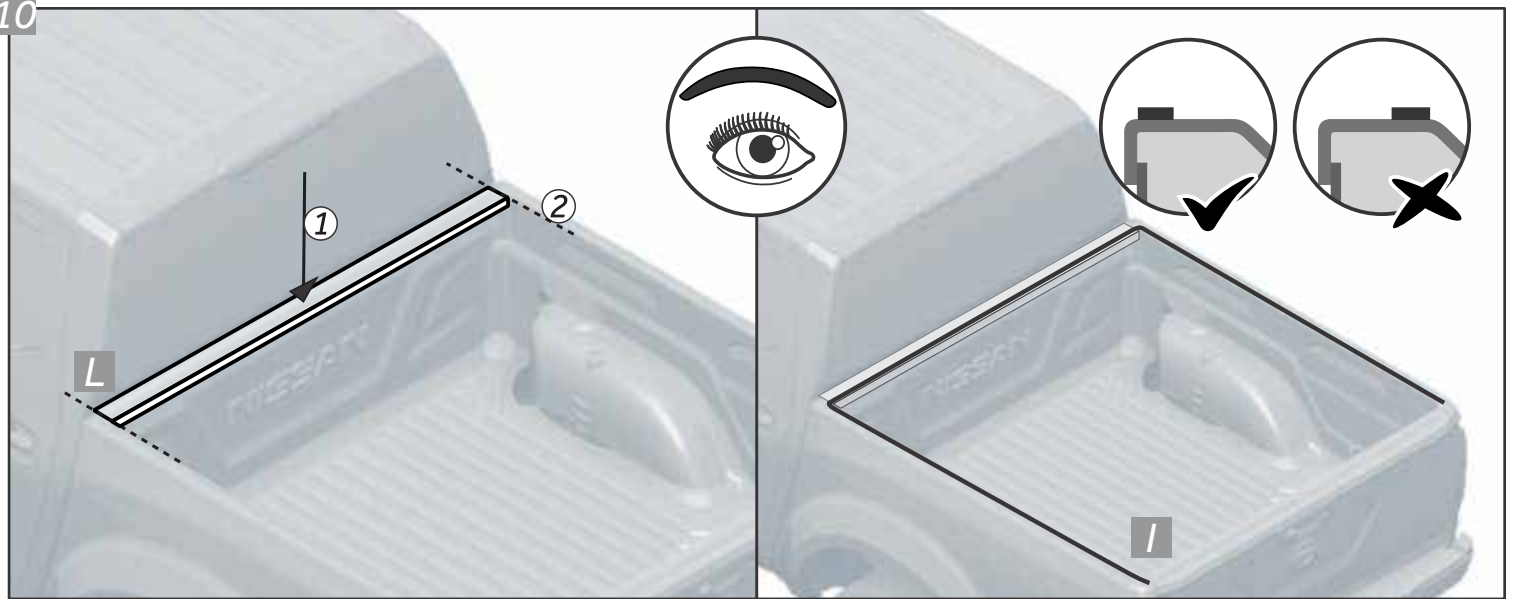

11

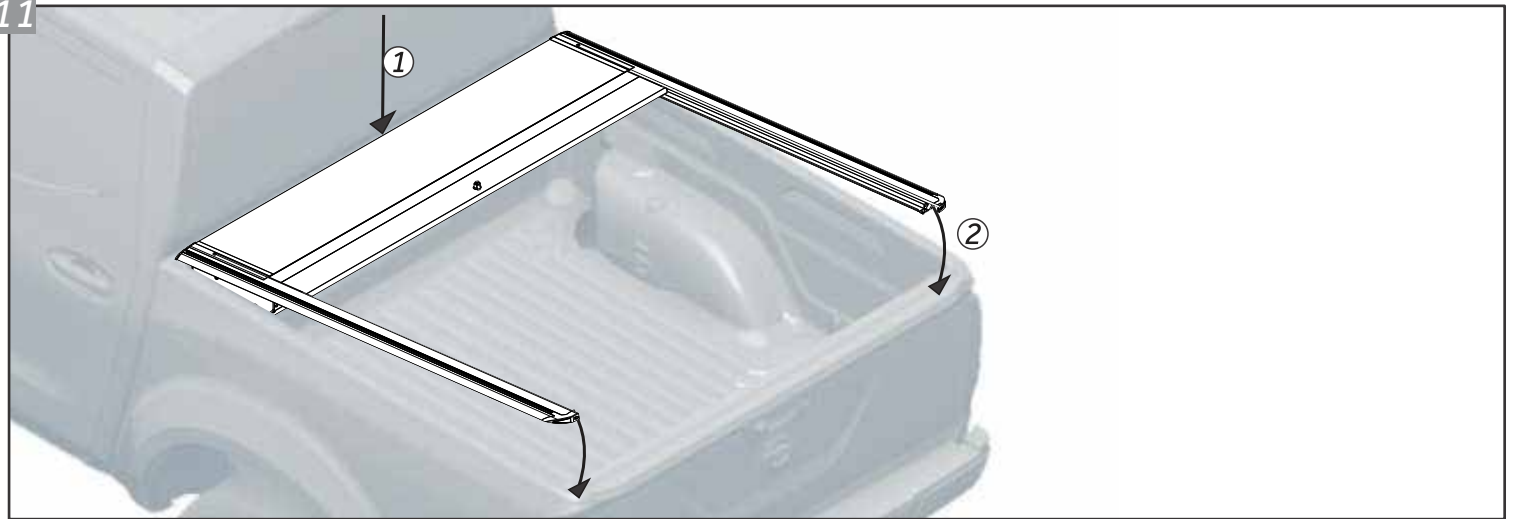

12

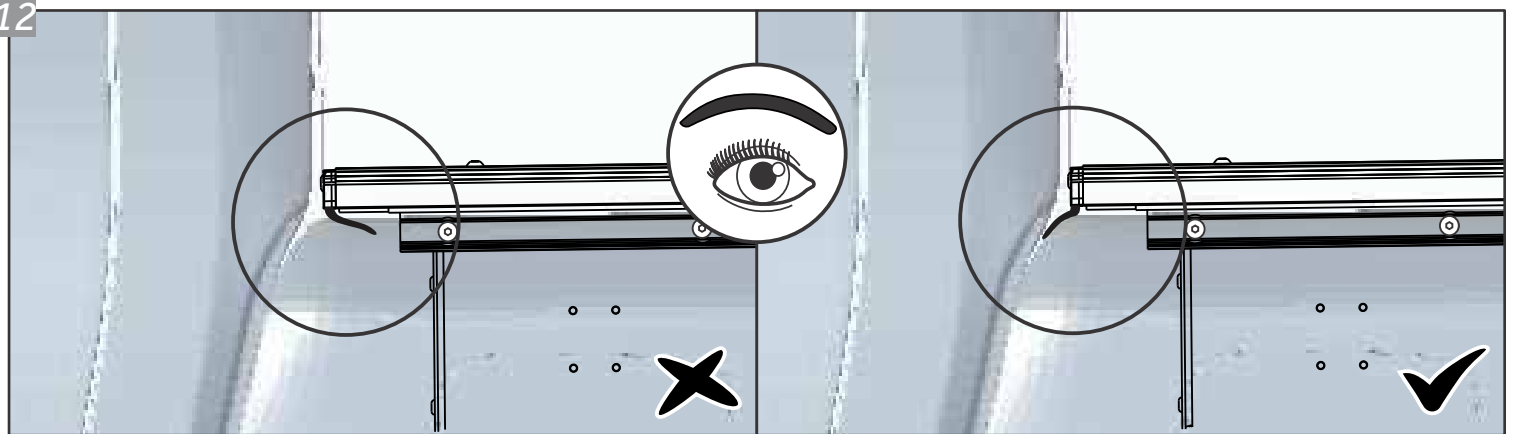

13



INSTALLATION INSTRUCTIONS

14

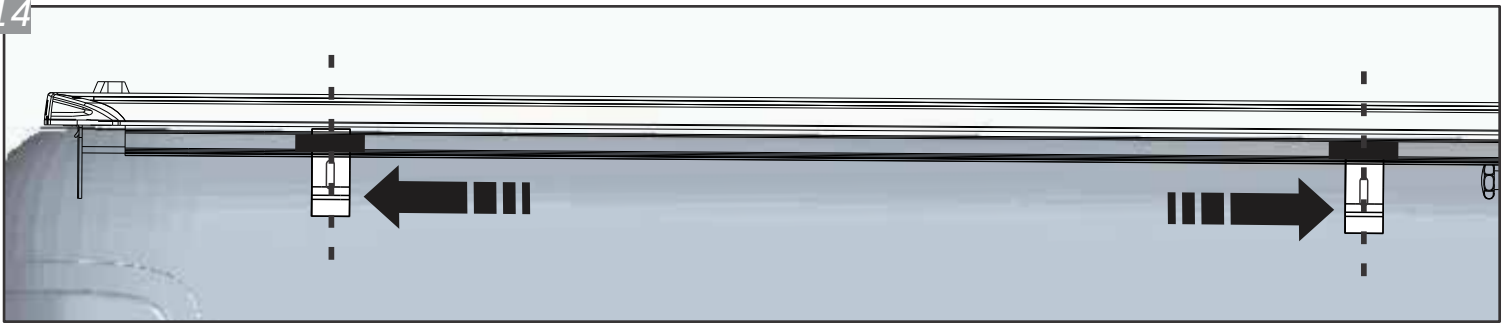

15

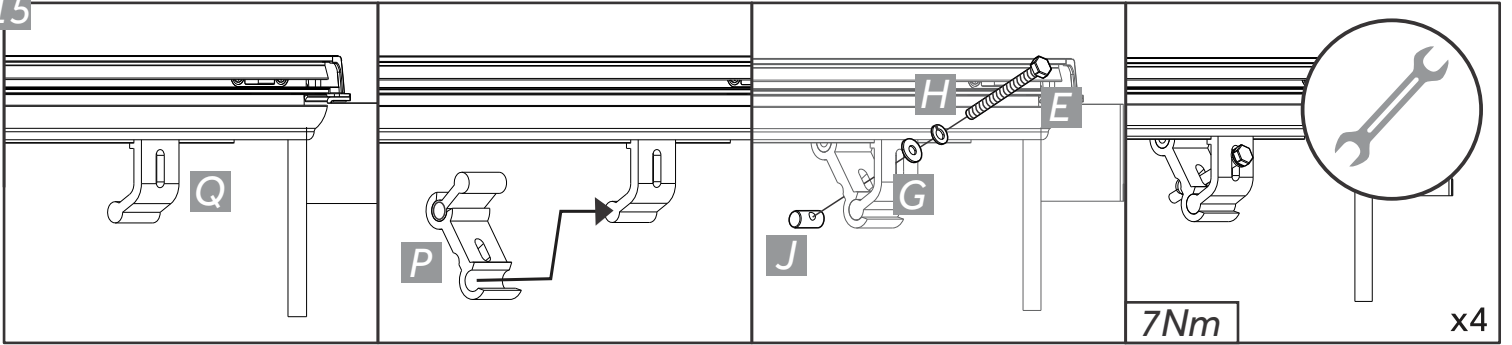

16

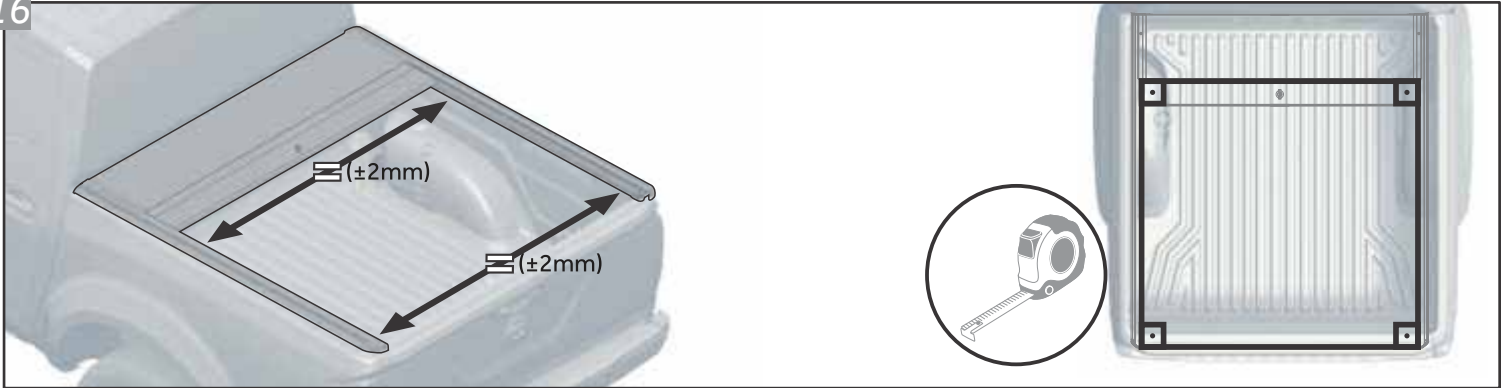

17

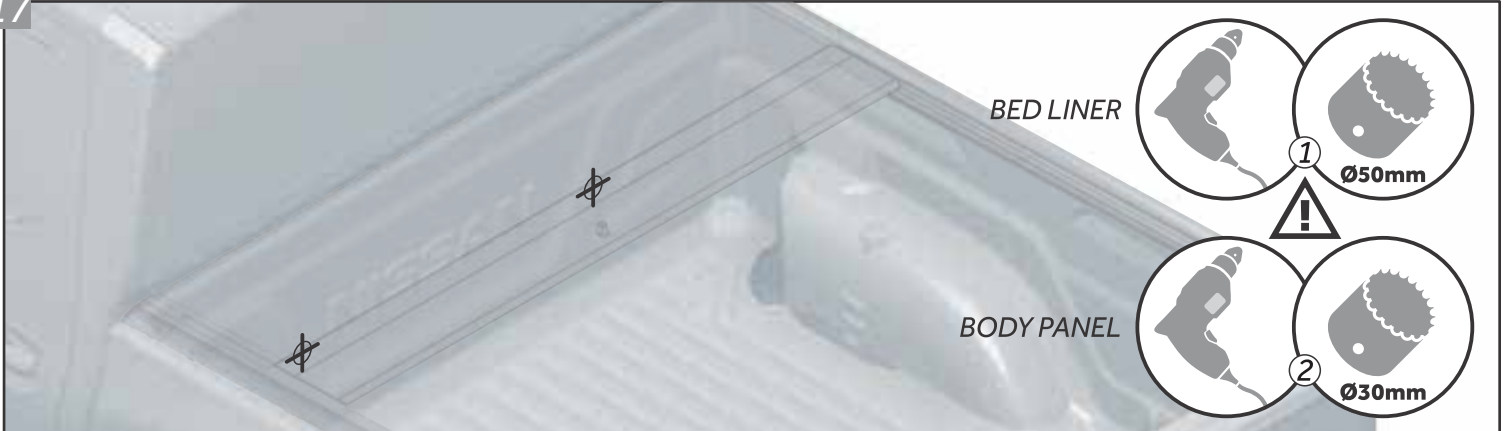

18

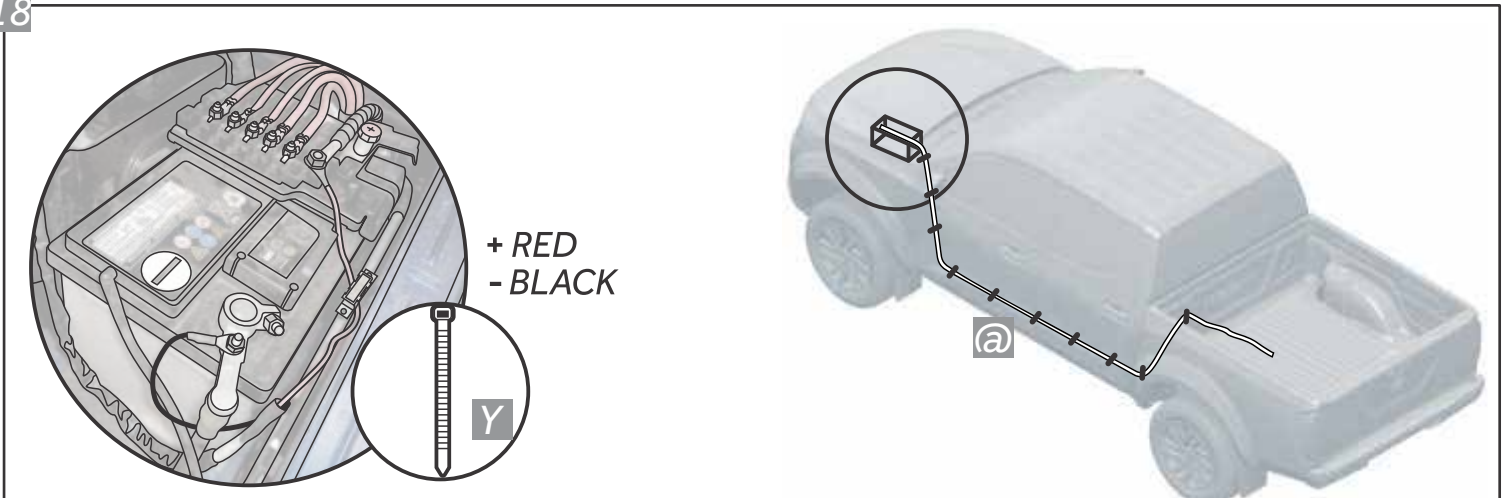

INSTALLATION INSTRUCTIONS

19

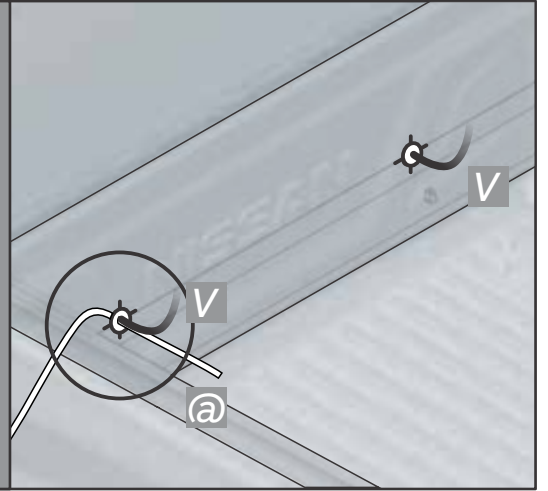
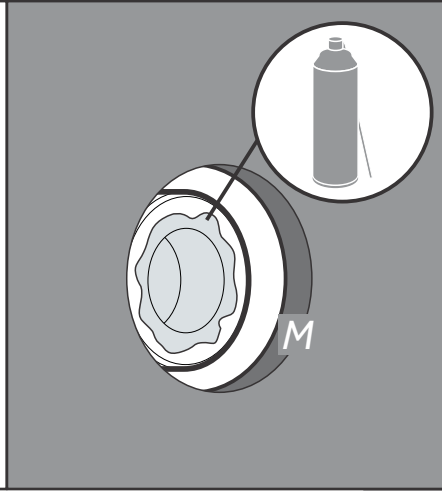
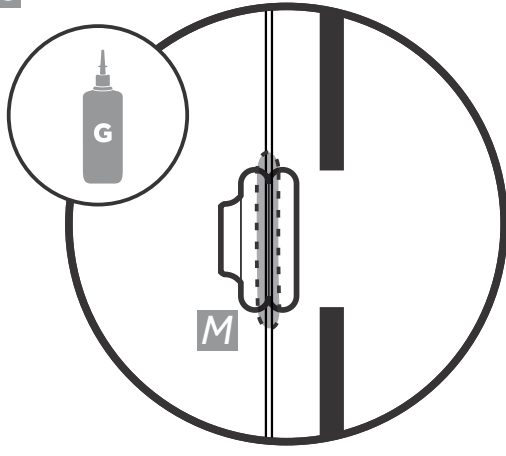

20

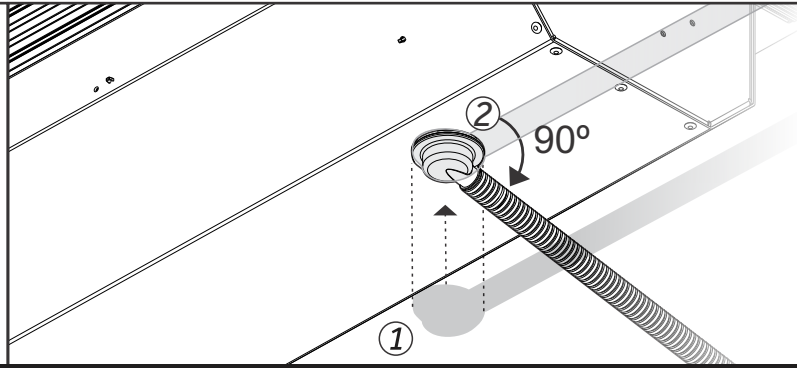
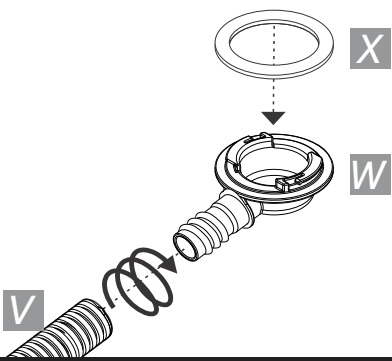

Repeat the procedure for the other side

21

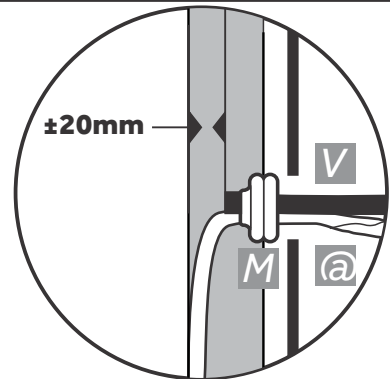

22

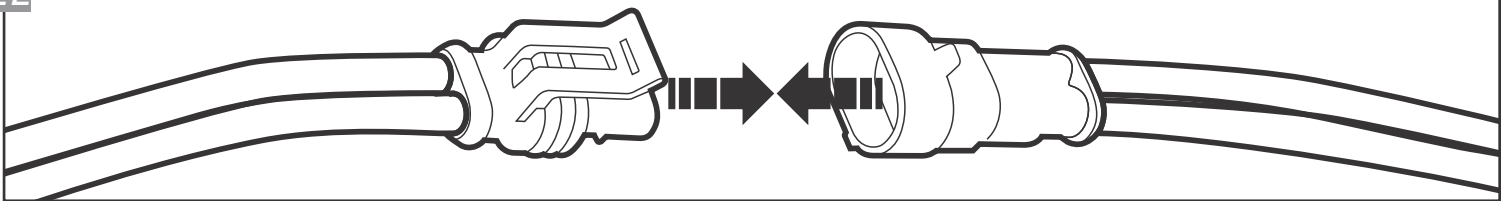

23



INSTALLATION INSTRUCTIONS

24

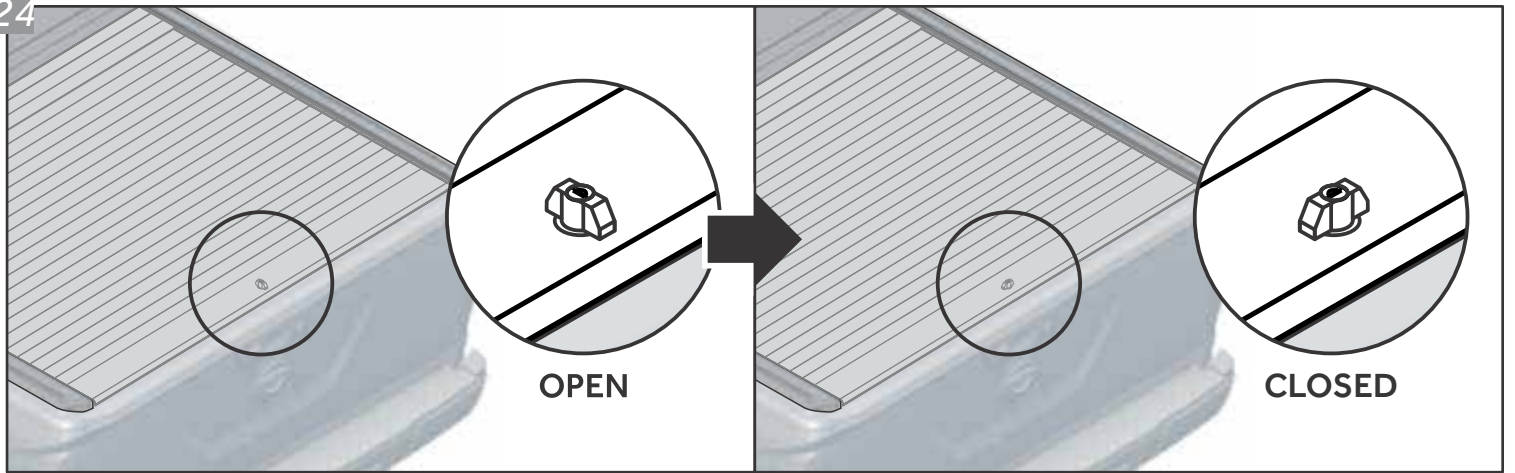

25

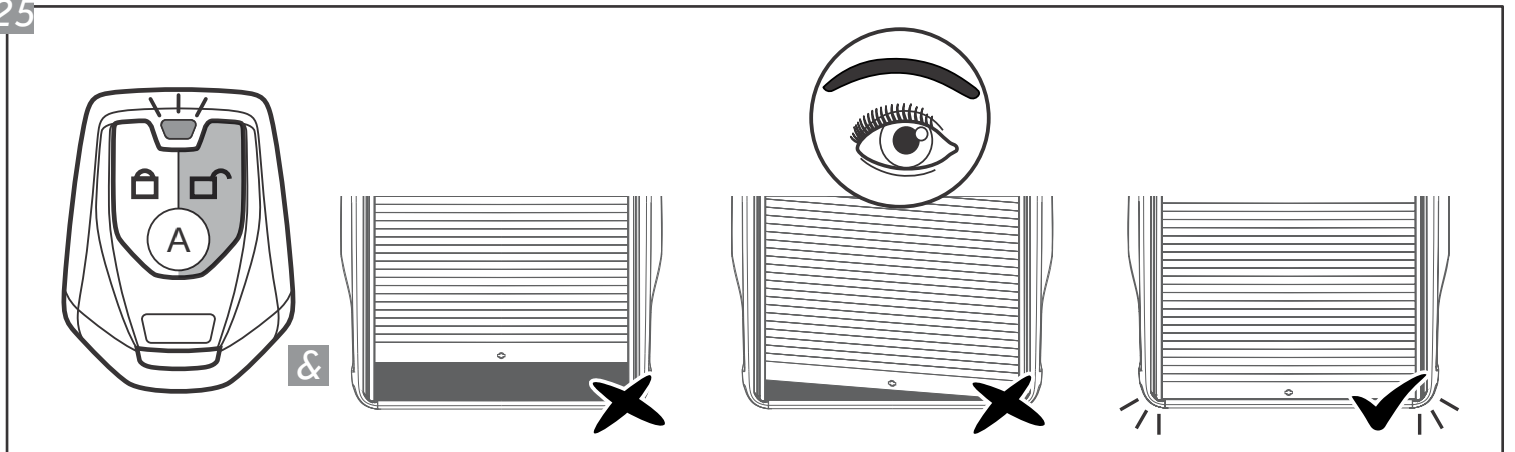

26

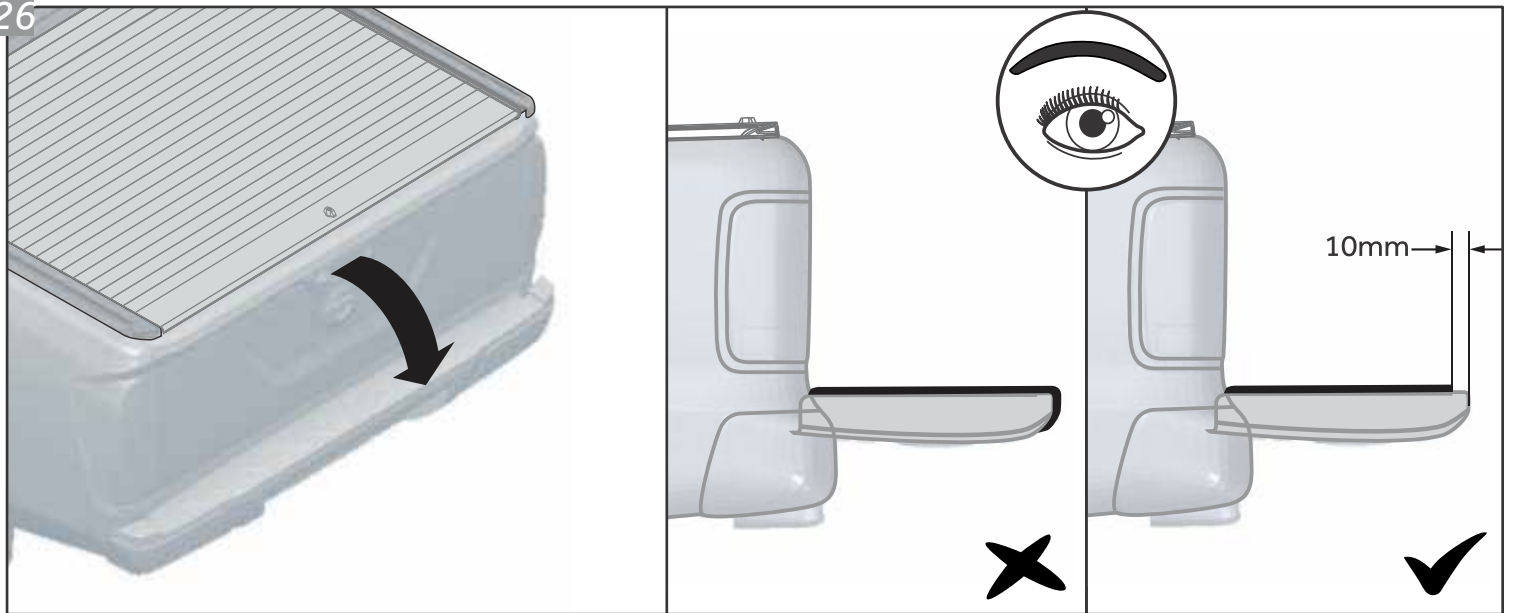

27

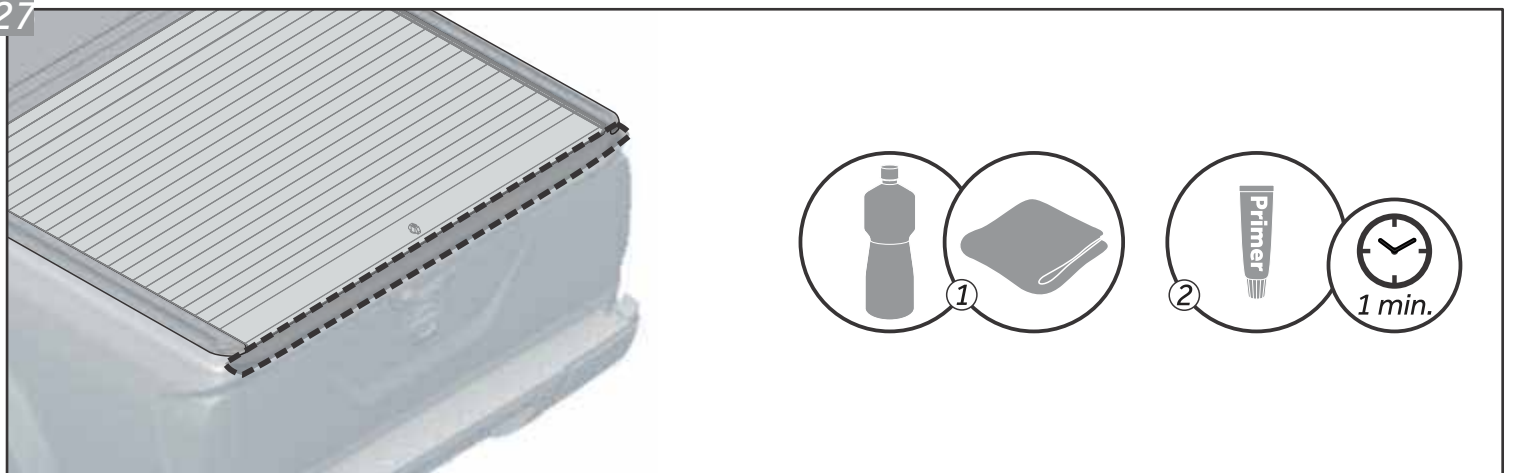

INSTALLATION INSTRUCTIONS

28

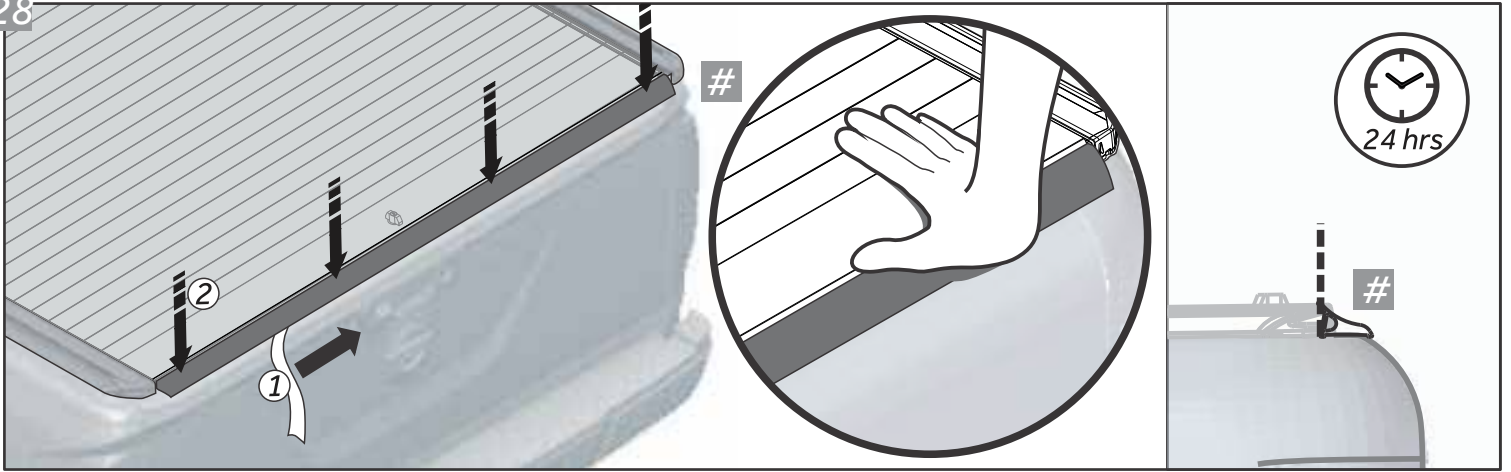

29

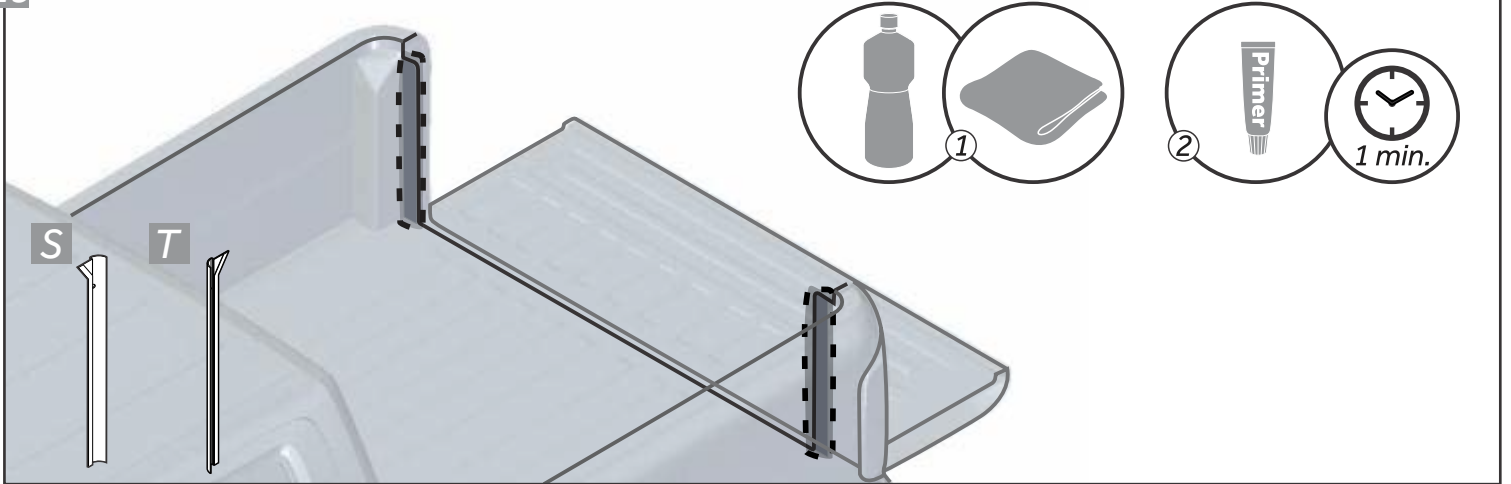

30

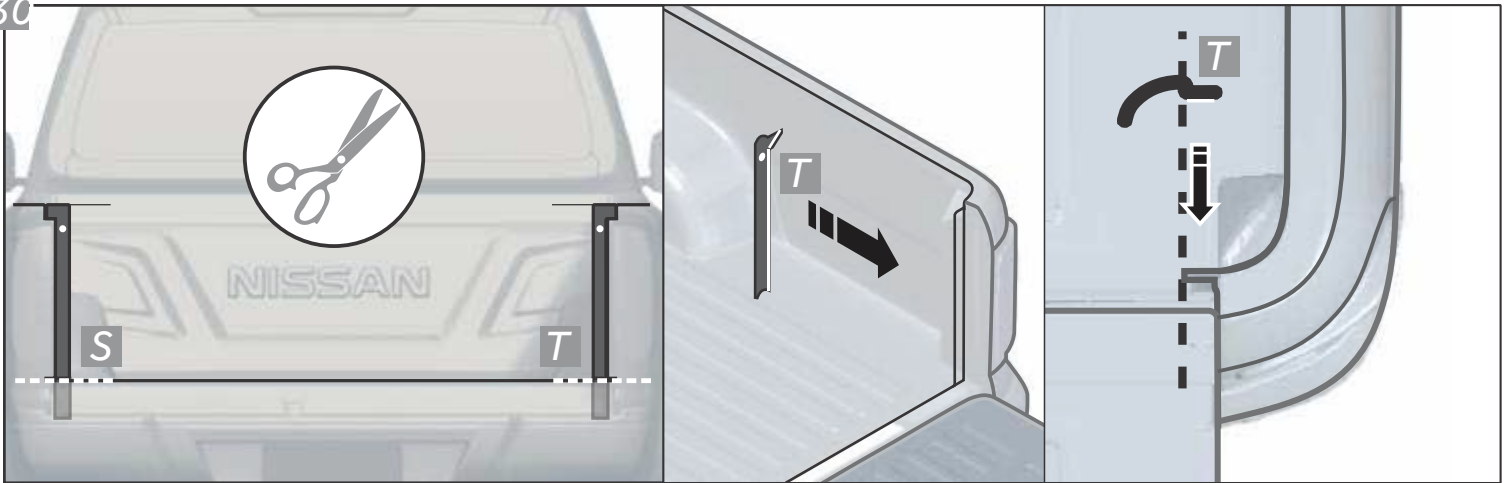

31

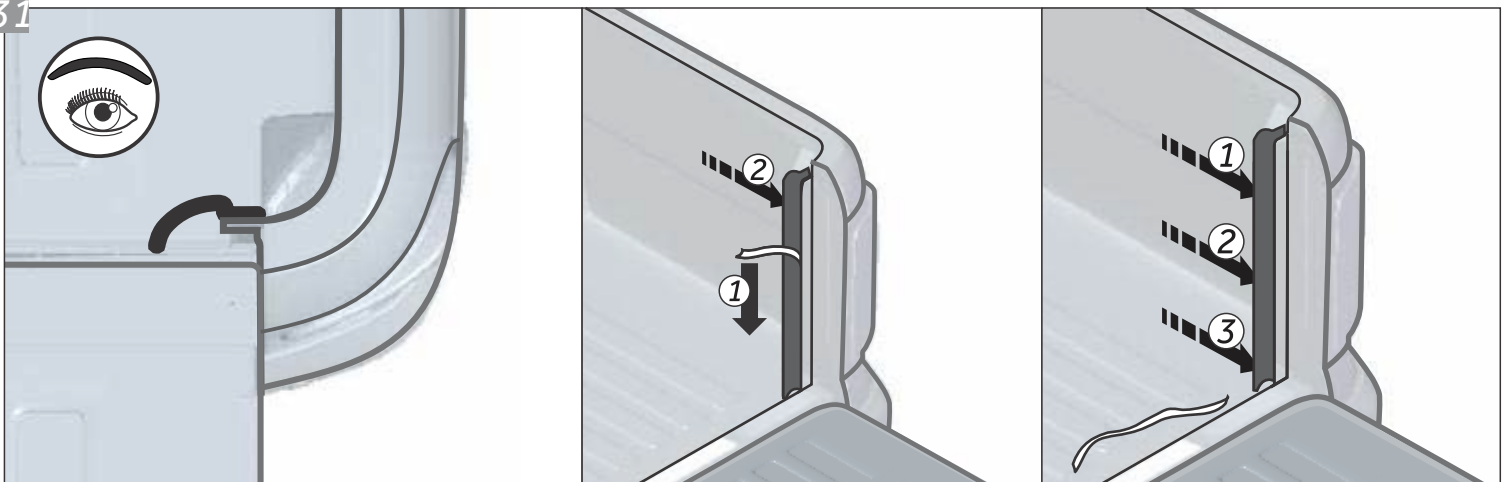

Repeat the procedure for the other side

INSTALLATION INSTRUCTIONS

32

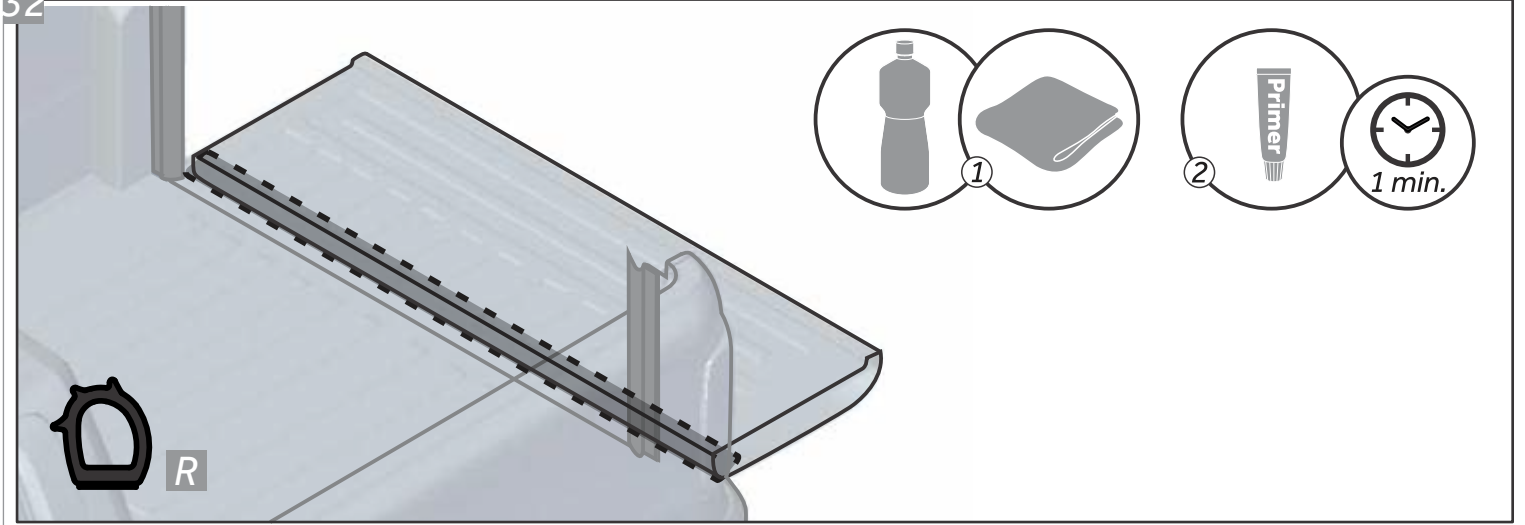

33

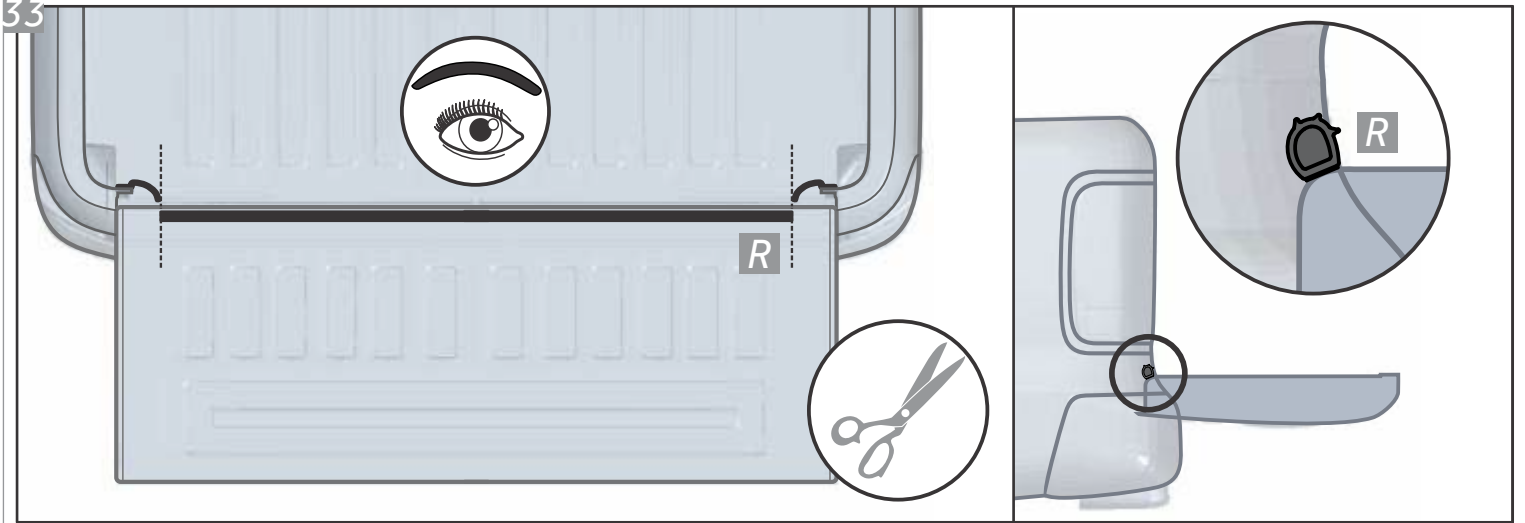

34

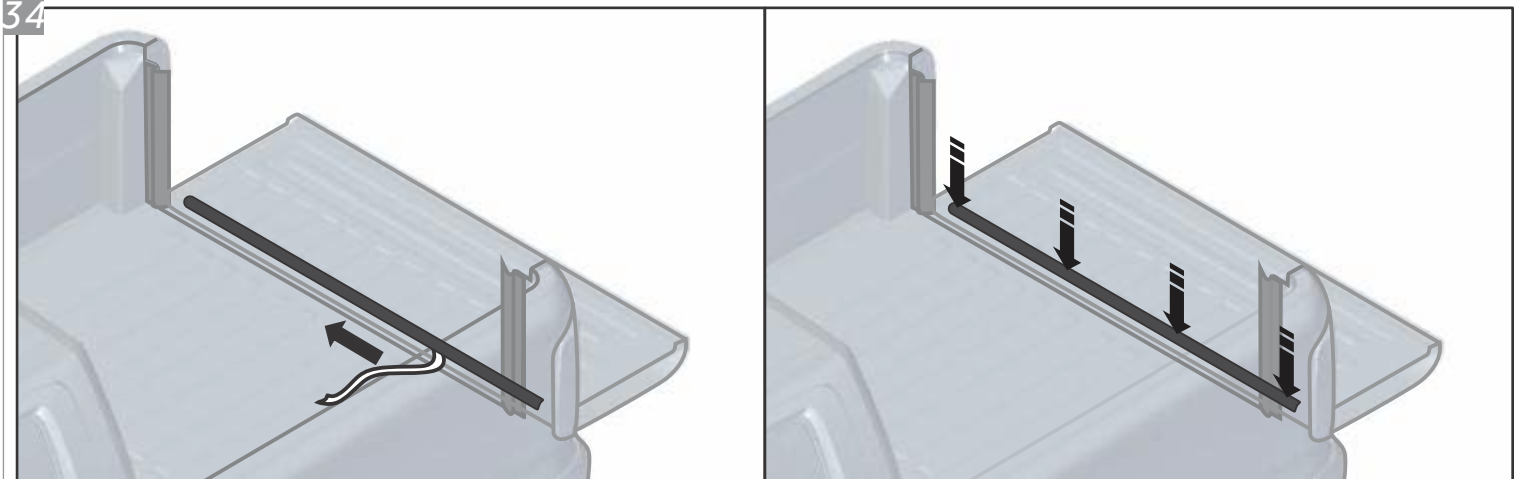

35 Repeat the procedure for the other side

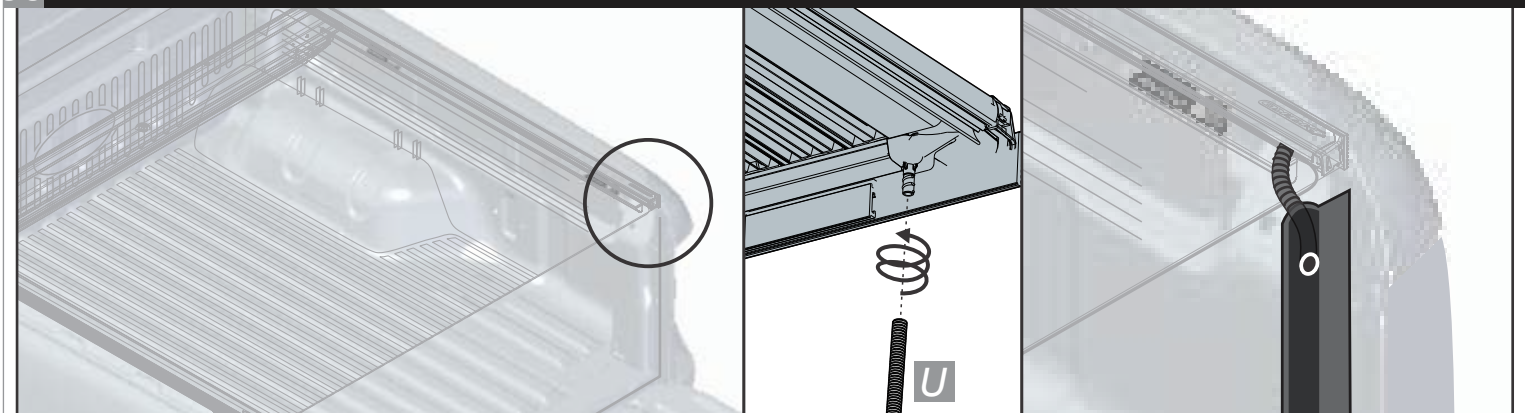

LUBRICATION

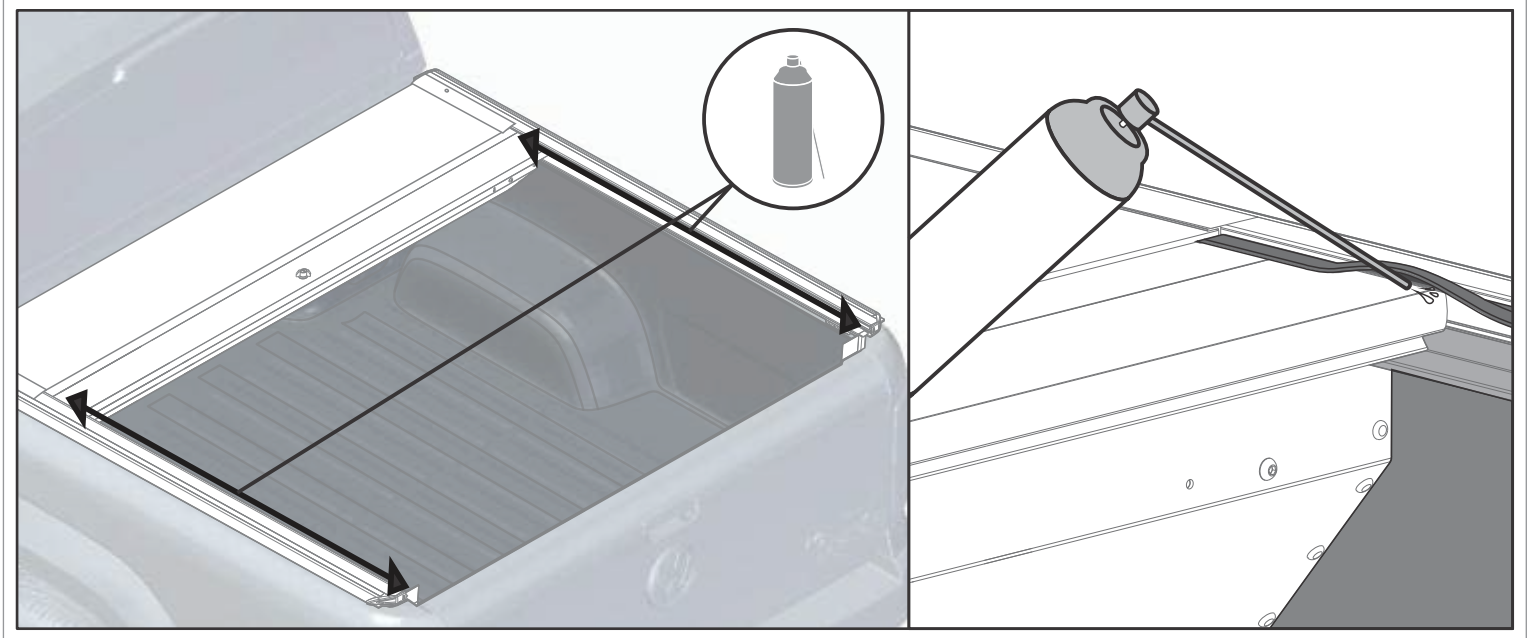

RVE SHUTTER LID INSTALLATION INSTRUCTIONS

FOR INSTALLATION GUIDES GO TO WWW.RVE.CO.NZ

V. 2.0
08.06.2021